

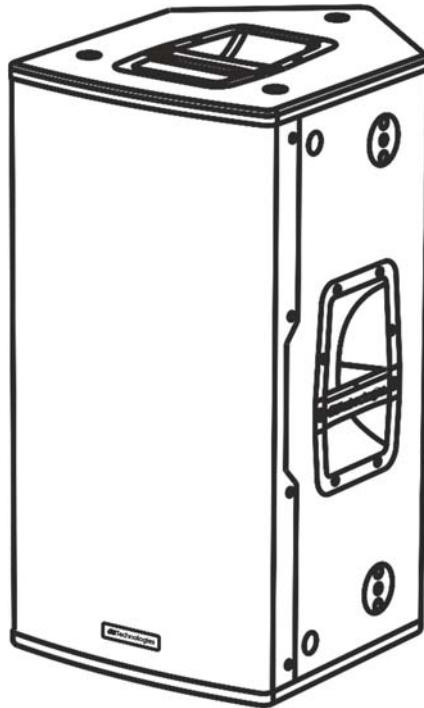

VIO X12

Professional Active 2-Way Speaker



Quick start user manual

Section 1

The warnings in this manual must be observed together with the "USER MANUAL - Section 2".

Le avvertenze nel presente manuale devono essere osservate congiuntamente al "MANUALE D'USO - Sezione 2".

Die Warnungen in diesem Handbuch müssen in Verbindung mit der "BEDIENUNGSANLEITUNG - Abschnitt 2" beobachtet werden".

Les avertissements spécifiés dans ce manuel doivent être respectés ainsi que les "CARACTERISTIQUES TECHNIQUES - Section 2"

Las advertencias del presente manual se deben tener en cuenta conjuntamente con las del "MANUAL DEL USUARIO" - Sección 2".

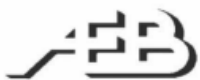

A.E.B. Industriale Srl Via Brodolini, 8 Località Crespellano 40053 VALSAMOGGIA BOLOGNA (ITALIA)
Tel +39 051 969870 Fax +39 051 969725 www.dbtechnologies.com info@dbtechnologies-aeb.com



Thank you for choosing a dBTechnologies Product!

VIO X12 is an active two-way loudspeaker, designed for professional use, equipped with one neodymium 1.4" compression driver (voice coil: 3") and one 12" neodymium woofer (voice coil: 3"). The powerful DIGIPRO® G3 amplifier section, capable of handling up to 900 W (RMS power), is controlled by a DSP, which can perform a detailed customization of the output sound of the loudspeaker. Thanks to the mechanical design and the complete control interface, it is possible to use VIO X12 in live scenarios and as a monitor on the stage, or for installations in medium/large venues. The RDnet connections allow in-depth remote control, thanks also to free available software (AURORA NET). Professional accessories (like a rain cover, or vertical WB-VIOX12V and horizontal WB-VIOX12H wall brackets) ensure versatility and an easy set-up.

Check the site www.dbtechnologies.com for the complete user manual!

1) Unpacking

The box contains:

No. 1 VIO X12

No. 1 Mains cable with Neutrik® powerCON TRUE1 connector

No. 1 Fuse for the use in the 100-120V~ range.

This quick start and warranty documentation

2) Easy installation

The easy use in different configurations is guaranteed by:

All those mechanical particulars were thought for an easy use and for different configuration needs. VIO X12 is perfect for live shows as well as medium/large venue installations. The acoustical design allows to face different environments.

As shown in the following picture, the related dispersion pattern data are:

a) horizontal coverage: 60°

b) vertical coverage: 40°

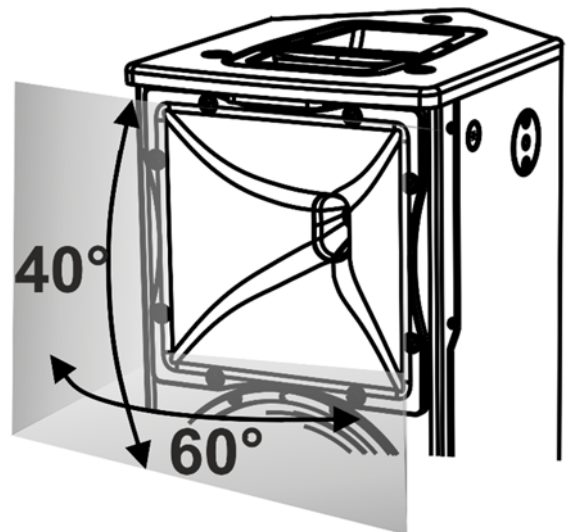
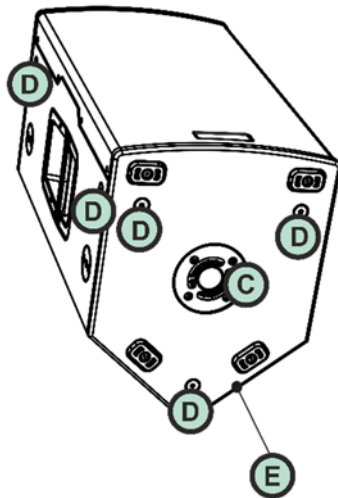
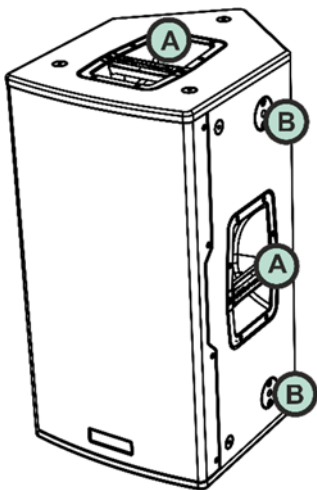

- **handles [A]**, on the top and for each side
- **fast pin locks [B]**, 2 for each side, for the usage in installation with WB-X12V wall-brackets
- **pole mount adapter [C]**, 36 mm diameter
- **12 pick points [D]**, with M10 threaded holes for the usage in installation with WB-X12H wall brackets, or for the use of eyebolts (not supplied)
- **tilted side [E]**, (angle: 50°) for the use as live stage monitor



The product and accessories must be handled by trained personnel only! The user is required to follow regulations and mandatory laws on safety of the country in which the product is used. Don't use the handles to suspend VIO X12!

3) First switch-on

The DIGIPRO G3 amplifier of VIO X12 is controlled by a powerful DSP. All the connections and controls are in the rear amplifier control panel:

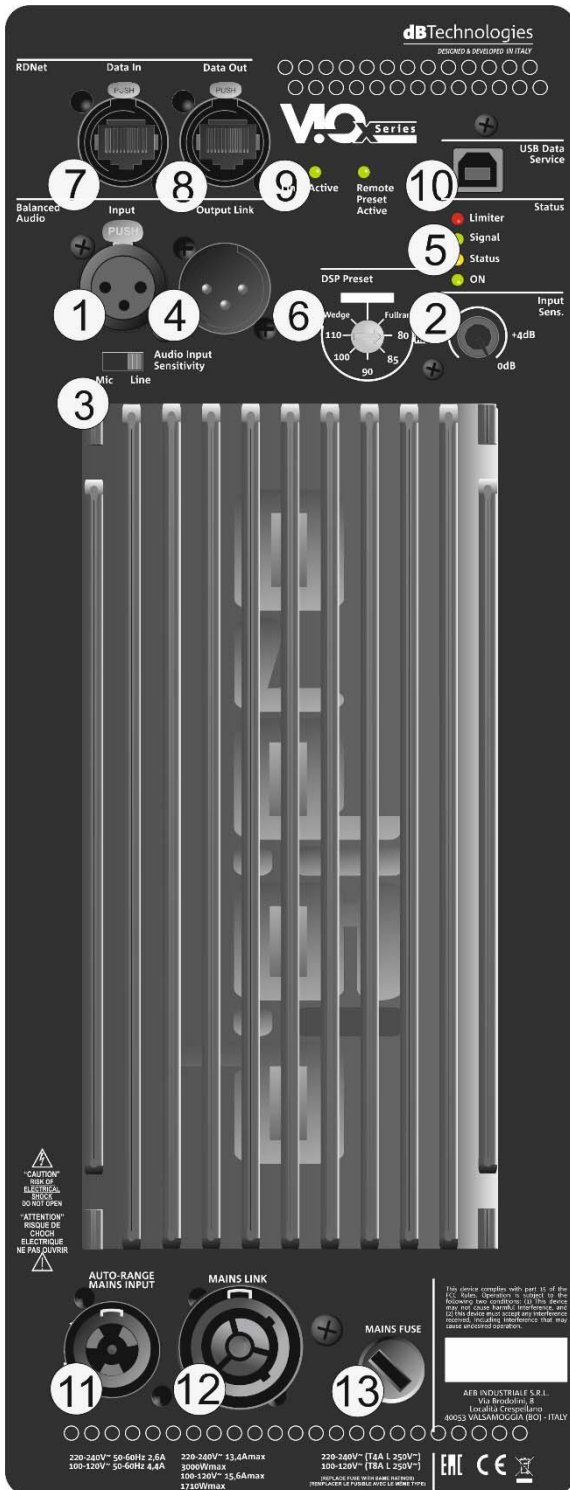

- 1 – Input (balanced) connector
- 2 – Input sensitivity potentiometer
- 3 – Audio Input Sensitivity switch (MIC/LINE)
- 4 – Output Link (balanced) connector
- 5 – Status LEDs (Limiter, Signal, Status, On)
- 6 – DSP Preset rotary control
- 7 – RDNet Data In
- 8 – RDNet Data Out
- 9 – RDNet status LEDs
- 10 – USB Data Service (USB-standard Type B)
- 11 – Mains Input connector
- 12 – Mains Link connector
- 13 – Mains Fuse

- a) Once you have properly set up the desired configuration (see also the VIO X12 complete user manual and accessories instructions for further information), connect the audio input (1). In case of dynamic microphone, select “MIC” in Input Sensitivity Switch [3], otherwise select “LINE”. Please note that this parameter can be selected only on the control panel, it cannot be remotely controlled. Adjust the Input Sensitivity level [2] to 0 dB.
- b) If you need to send the audio signal to a second speaker, connect the “Output Link” [4] to the Input [1] of another VIO X12 (for example) using a cable with XLR (balanced) connector.
- c) Set properly the DSP Preset rotary [6], choosing between “Fullrange” or “Wedge” configurations, or apply a specific HPF filter frequency (cut-off: 80/85/90/100/110 Hz).
- d) In case of remote control, connect the proper Data Input [7] to the hardware remote controller (RDNet Control 2 or RDNet Control 8) with cables equipped with etherCON connectors. Then connect the Data Output [8] to the Data Input [7] of a second VIO X12, and so on. When the RDNet network is on and it has recognized the connected device, the LED “Link” [9] is on. The other LED [9] “Active” starts blinking when there is the presence of data transmission, the “Remote Preset Active” advises that the local controls set on the amplifier panel (level, DSP presets, etc.) are by-passed and controlled remotely by AURORA NET software. See also RDNet Control 2, RDNet Control 8 and AURORA NET user manuals for further information.
- e) Plug the mains Input [11] and Link [12] (powerCON) cables.

Check the complete user manual on www.dbtechnologies.com for further information about the system and available accessories.

Scarica il manuale completo da www.dbtechnologies.com per ogni ulteriore informazione sul sistema e sugli accessori disponibili.

Für weitere Informationen und verfügbares Zubehör lesen sie bitte die vollständige Bedienungsanleitung unter www.dbtechnologies.com.

Vérifiez le manuel de l'utilisateur complet sur www.dbtechnologies.com pour des informations complémentaires du système et des accessoires disponibles. Compruebe el manual de usuario completo sobre www.dbtechnologies.com para la información adicional sobre el sistema y accesorios disponibles.

The loudspeaker is supplied with a mounted fuse for operation within the 220-240V~ range. If you need to operate in the 100-120V~ voltage range:

- **Disconnect all connections, including the power supply**
- **Wait 5 minutes**
- **Replace the fuse with the one provided in the package for the 100-120V~ range**

Technical Data

Speaker Type: active 2-way loudspeaker

Acoustical data

Frequency Response [-6 dB]: 79 Hz - 21 kHz

Frequency Response [-10 dB]: 62 - 22 kHz

Max SPL (1 m): 132 dB

HF: 1 x 1.4", Neodymium

HF Voice Coil: 3"

LF: 1 x 12", Neodymium

LF Voice Coil: 3"

Crossover freq.: 1000 Hz (24 dB/oct)

Directivity (HxV): 60° x 40° (rotatable)

Amplifier

Amp Technology: Digipro® G3

Power supply: Auto-range

Amp Class: Class-D

RMS Power: 900 W

Peak Power: 1800 W

Cooling: Passive (convection)

Operating voltage:

220-240V~ / 100-120V~ 50-60 Hz (Auto Range)



Processor

Controller: DSP, 28/56 bit

AD/DA converter: 24 bit, 48 kHz

Advanced DSP functions: FIR filters

Limiter: Peak, RMS, Thermal

Controls: Rotary Encoder (presets), Input Sensitivity potentiometer, Mic/Line switch, LEDs

Input / Output

Mains connections: PowerCON® TRUE1 In/link

Maximum number of VIO X12 for each daisy chain

power connection [mains input + mains link]:

1+5* (220-240V~), 1+3** (100-120V~)

Signal Input: (Balanced) 1x IN (female) XLR connector

Signal Out: (Balanced) Link OUT (male) XLR connector

RNET connectors: Data In / Data Out

USB connector: standard USB B-type (for SERVICE DATA)

Mechanics

Housing: Wooden box/black polyurea finish

Grille: Full metal (CNC machining)

Handles: 1 on top

Rigging points: 12 M10 Threaded holes + 4 fast pin locks

Width: 340 mm (13.38 in)

Height: 650 mm (25.5 in)

Depth: 445 mm (17.51 in)

Weight: 20.7 kg (45.63 lbs.)

POWER SUPPLY SPECIFICATIONS (POWER ABSORPTION)

Draw at 1/8 of full power in average use conditions (*): 1.3 A (220-240V~) – 2.1 A (100-120V~)

Draw at 1/3 of full power in maximum use conditions (**): 2.6 A (220-240V~) – 4.4 A (100-120V~)

Power absorption with speaker turned on without signal (idle): 19 W

* **INSTALLER NOTES:** The values refer to 1/8 of full power, in average operating conditions (music program with infrequent or no clipping). It is recommended to consider them the minimum sizing values for any type of configuration.

** **INSTALLER NOTES:** The values refer to 1/3 of full power, in heavy operating conditions (music program with frequent clipping or activation of the limiter). We recommend sizing according to these values in case of professional installations and tours.

Download the complete user manual on: www.dbtechnologies.com/EN/Downloads.aspx

EMI CLASSIFICATION

According to the standards EN 55103 this equipment is designed and suitable to operate in E3 (or lower E2, E1) Electromagnetic environments.

FCC CLASS B STATEMENT ACCORDING TO TITLE 47, PART 15, SUBPART B, §15.105

This equipment has been tested and found to comply with the limits for a Class B digital device, pursuant to part 15 of the FCC Rules.

These limits are designed to provide reasonable protection against harmful interference in a residential installation.

This equipment generates, uses and can radiate radio frequency energy and, if not installed and used in accordance with the instructions, may cause harmful interference to radio communications.

However, there is no guarantee that interference will not occur in a particular installation. If this equipment does cause harmful interference to radio or television reception, which can be determined by turning the equipment off and on, the user is encouraged to try to correct the interference by one or more of the following measures:

1. Reorient or relocate the receiving antenna.
2. Increase the separation between the equipment and receiver.
3. Connect the equipment into an outlet on a circuit different from that to which the receiver is connected.
4. Consult the dealer or an experienced radio/TV technician for help.

Changes or modifications not expressly approved by the party responsible for compliance could void the user's authority to operate the equipment.

WARNING: Make sure that the loudspeaker is securely installed in a stable position to avoid any injuries or damages to persons or properties. For safety reasons do not place one loudspeaker on top of another without proper fastening systems. Before hanging the loudspeaker check all the components for damages, deformations, missing or damaged parts that may compromise safety during installation. If you use the loudspeakers outdoor avoid spots exposed to bad weather conditions.

Contact dB Technologies for accessories to be used with speakers. dBTechnologies will not accept any responsibility for damages caused by inappropriate accessories or additional devices.

Features, specification and appearance of products are subject to change without notice.

dBTechnologies reserves the right to make changes or improvements in design or manufacturing without assuming any obligation to change or improve products previously manufactured.